

# H<sub>2</sub>S IN LIQUIDS PROCESS ANALYZER

Model 205 PermaStream | Crude Oil, Fuel Oil, Dirty/Clean Water, Drilling Fluid, Condensate, Diesel



## Product Features

- Real-time & accurate measurement
- Measure H<sub>2</sub>S in crude, water, diesel, etc.
- Specific to H<sub>2</sub>S only, no false positives ever
- No field calibrations required
- No liquid sample conditioning required
- No sample filters required
- Only one tap-point needed for sample exit and return (when pitot probe is utilized)
- Fast response time
- Proven reliability
- Conformity to ASTM methods
- Set in-line at process pressure and flow

## Applications

- Crude Oil (light/medium/heavy) • Dirty/clean Water • Diesel • Fuel Oil • Drilling Fluid • Condensate • Quality control
- Corrosion control • Transportation safety • Loading/unloading of trucks, rail cars, pipelines, etc. • Compliance

**No 'false positives'** The only detection method specific to H<sub>2</sub>S only, proven by thousands of applications

**Ultra low-maintenance** Advanced Colorimetric-Rateometric Detector is guaranteed hassle-free for long term operation

**Dependable operation** No sample conditioning required; no filters, no pressure regulators, no pumps required

**No field calibrations** The analyzer does not require calibrations in the field even with unexpected process changes

## Product Description

The effective procedure to measure H<sub>2</sub>S in crude oil and other opaque liquids requires the representative stripping of the H<sub>2</sub>S from the liquid into the gas phase for analysis by a gas H<sub>2</sub>S analyzer or sensor. Traditionally, headspace stripping columns have been used for this purpose but have become infamous for being problematic, high maintenance, and requiring many moving parts that break down over time.

Analytical Systems has overcome the shortfalls of the headspace stripping column by developing a reliable alternative; the state-of-the-art PermaStream utilizing KECO Membrane Technology. The PermaStream efficiently and reliably separates the H<sub>2</sub>S from the liquid sample for measurement in the gas phase by the H<sub>2</sub>S analyzer which is specific only to H<sub>2</sub>S and does not suffer from false positives. The PermaStream is a simple device that continuously provides an ultra-clean and dry sample to the H<sub>2</sub>S sensor. This results in radically reduced maintenance when compared to the headspace stripping column.

Analytical Systems is established as the world-wide leader in H<sub>2</sub>S in liquids analysis online due to the many benefits of PermaStream's exclusive technology. The 205 PermaStream is capable of measuring in ppb, ppm or even percent ranges and will never suffer from false-positives like other H<sub>2</sub>S detection methods.

# KECO

Phone (281) 516-3950 or (281) 664-2890  
sales@kecosystems.com | service@kecosystems.com

www.LiquidGasAnalyzers.com

# Typical Specifications

## DISPLAY

- Alpha Numeric LCD
- 128 x 64 pixel
- Back-lit display

## TEMPERATURE RANGES

- 1°C to 50°C (operating) without cooling/heating
- 0°C to 70°C (storage)

## ANALOG

- 4-20mA Isolated

## ANALYTICAL PERFORMANCE

- Resolution: 1 ppb
- Accuracy:  $\pm 2\%$
- Repeatability:  $\pm 1\%$
- Linearity:  $\pm 1\%$
- Drift: Nil
- Temp. Coefficient: 0.01% / °C
- Analysis time: 0.75 Second

## DETECTION RANGES

- 0-1 ppm
- 0-10 ppm
- 0-50 ppm
- 0-100 ppm
- 0-500 ppm
- Percent ranges
- Customer specified (contact factory)

## SAMPLING SYSTEM

- Carrier Air/Gas requirement: 15 psig constant and 150 ml/min flow rate
- Liquid requirement: Minimum 0.5 L/min flow and maximum 1,500 psig

## WEIGHT

- ~175 lbs (analyzer only, no options)

## DIMENSIONS

- 3 ft X 3 ft X 1.5 ft

## UTILITIES/SETTINGS

- 110VAC or 220VAC
- 100 Watts normal, 700 Watts max
- Carrier Air/Gas: 180 ml/min (15 psig max)
- Sample flow: 0.5 L/min minimum
- Sample pressure: 1,500 psig max

## AREA CLASSIFICATIONS

- Class 1 Division 1
- Class 1 Division 2
- Zone 1 or Zone 2

## AVAILABLE OPTIONS

- Concentration relay alarms
- Diagnostic/fault relay alarms
- Low flow relay alarms
- RS-232/485 Modbus
- Data Logger for data download to PC
- Remote monitoring/control with PC
- Automatic calibration

## TECHNOLOGIES

- PermaStream™(ASI Membrane Technology)
- Rateometric-Colorimetric Tape

## Advantages

**No 'false positives'** The only detection method specific to H<sub>2</sub>S only, proven by thousands of applications

**Ultra low-maintenance** Advanced Colorimetric-Rateometric Detector is guaranteed hassle-free for long term operation

**Dependable operation** ASI Membrane Technology eliminates liquid carry-over that plague **headspace stripping columns**

**No field calibrations** The analyzer does not require calibrations in the field despite any unexpected process changes

KECO provides design and application engineering assistance for the User's analyzer requirements. For a quotation, please complete Analyzer Quote Request Form at [www.LiquidGasAnalyzers.com/quote](http://www.LiquidGasAnalyzers.com/quote)



## Advantages of KECO Tape Detector For PermaStream H<sub>2</sub>S in Liquids Analyzers

- ✓ **Specific only to H<sub>2</sub>S** No known cross-interferences proven by thousands of world wide applications
- ✓ **No calibrations required** Based on exclusive KECO Membrane Technologies and advanced Tape detector
- ✓ **Analyzer measurements correlates to ASTM analytical method**
- ✓ **Automatic self-zero** The KECO H<sub>2</sub>S analyzer does not suffer from a 'zero drift' as seen in other analyzers thus eliminating zero gas requirements
- ✓ **Versatile** The analyzer will not suffer in the event of process changes no matter how drastic
- ✓ **Wide Range Ability** The analyzer is capable of measuring from the PPB levels through PPM up to saturation
- ✓ **Hassle free** KECO advanced Tape detector only needs 2 to 4 tape changes per year (typical) on standard 100 foot tape roll
- ✓ **Linear Response** The analyzer is innately linear in response, no need to calibrate in the field
- ✓ **Field-proven technology** The PermaStream analyzer is field-proven by installations all over the world and trusted by major oil & gas companies worldwide including Preferred Vendor status

(281) 516-3950 FAX (281) 351-8925

[Sales@kecosystems.com](mailto:Sales@kecosystems.com) or [support@kecosystems.com](mailto:support@kecosystems.com)  
[www.asikeco.com](http://www.asikeco.com)



## Field Calibrations Not Required for Model 205

The 205 series H<sub>2</sub>S in Liquids Analyzers do not require routine calibrations in the field. This is due to the long-term stability of the calibration performed in the factory laboratory that is measured in multiples of years. The analyzers maintain a stable factory calibration over many years as a result of two principle technologies: The Sample Transfer Stripper (STS) or PermaStream and the tape method detection technology.

Firstly, the STS or PermaStream in the 205 series analyzers creates an “ultra-pure” sample to the detector at all times. The liquid sample continuously passes one side of the permeable membrane. The H<sub>2</sub>S in the sample passes through the membrane as a representative gas phase. Clean and dry carrier air/nitrogen then sweep the H<sub>2</sub>S on the other side of the membrane to the detector. The membrane acts as an ideal filter preventing mists, debris and any liquids from passing thru the membrane and contaminating the detector. This makes an ideal environment for the detector at all times.

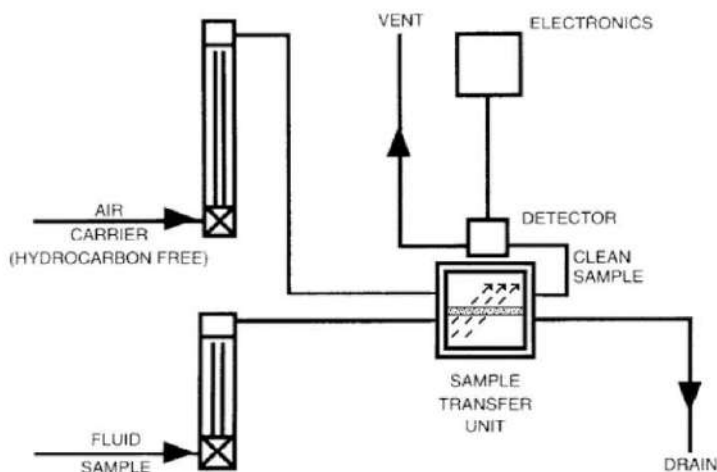

Secondly, the detection technology used in the 205 series analyzers is the ASTM approved colorimetric-radiometric tape method. The tape method is intrinsically linear and does not suffer “zero drift” or offset over time like traditional sensors. This is because the zero reading is irrelevant to the analysis. Measurement of hydrogen sulfide (H<sub>2</sub>S) concentration by the use of H<sub>2</sub>S sensing tape is based on the physical constants and chemical factors which are described in the following paragraphs.

The mathematical formulations demonstrate the calculation precision that is achieved by the application. Detection of H<sub>2</sub>S concentrations by the use of H<sub>2</sub>S sensing tape is achieved by exposing the film to an H<sub>2</sub>S sample through an aperture in the sample flow system, called the sample chamber. The reaction of photographic film to the light is an analogy to the way that chemically saturated H<sub>2</sub>S sensing tape reacts to hydrogen sulfide. The chemical formulation for this reaction is as follows:

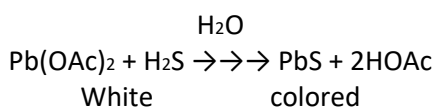

This reaction has three characteristics which allow it to be applied with unique analytical precision:

# KECO

1. The reactants are colorless (white).
2. The product (PbS) is colored.
3. In more than a century of use, hydrogen sulfide is the only reactant ever found that produces a colored product.

The analytical precision of this technology is ASTM approved (ASTM 4084-82).

The rate (r) of this reaction (forming PbS) is as follows:

$$r = k \text{Pb(OAc)}_2 \times \text{H}_2\text{S}$$

Where k, the proportionality factor, is called the rate constant.

NOTE: The very large (more than 1000 times) concentration of Pb(OAc)<sub>2</sub> on the H<sub>2</sub>S sensing tape simplifies the reaction as follows:

$$[\text{Pb(OAc)}_2]_0 = [\text{Pb(OAc)}_2]_1 - \text{PbS}_1 = K_2$$

$$(<.1\%) \text{ Therefore, } r_n = k k_2 (\text{H}_2\text{S} - \text{PbS}_n)$$

$$\text{For simplicity } k k_2 = K$$

$$r_n = K(\text{H}_2\text{S} - \text{PbS}_n)$$

By maintaining a constant H<sub>2</sub>S concentration, with continuous flow of the sample into the sample chamber, the rate of reaction equation is further reduced to:

$$r = K\text{H}_2\text{S}$$

Therefore, by maintaining the control conditions of:

1. A constant quantity of Pb(OAc)<sub>2</sub>
2. Constant H<sub>2</sub>S concentration.
3. Constant moisture
4. Constant flow rate

then the rate of reaction (i.e. the rate of darkening) is linearly proportional H<sub>2</sub>S concentration.

Measuring the rate of darkening is therefore directly equivalent to measuring the H<sub>2</sub>S concentration.

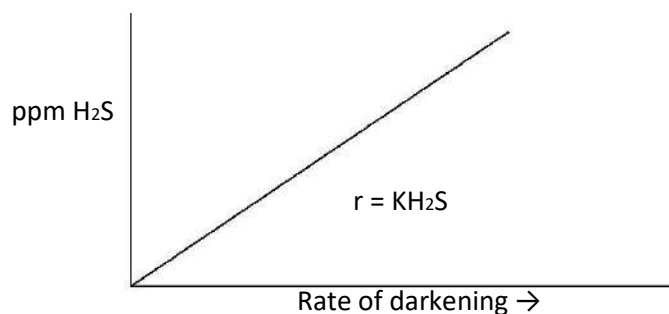

# KECO

In actual practice, the rate of darkening is determined by measuring the change in darkness from second to second.

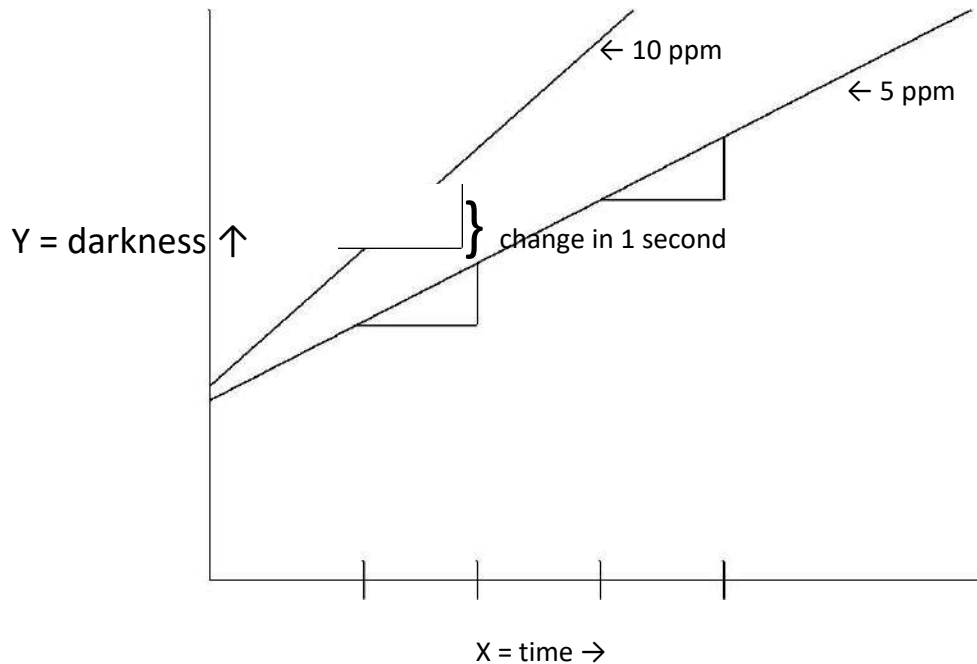

In other words, you don't care how dark the spot is, only how fast it is getting darker. This is like the highway patrol officer. He does not care how far you have driven, only how fast you are going right now. This is why the tape method of analysis does not suffer from a zero drift.

The Sample Transfer Stripper or PermaStream combined with the tape method of detection gives the 205 series H<sub>2</sub>S in Liquids analyzer a calibration stability measured in multiples of years. This means field calibrations are rarely, if ever recommended.

However, if calibrations are required as part of a standard method or local facility requirements, a simple gas phase calibration can be performed with an H<sub>2</sub>S standard bottle balanced with air or nitrogen. However, it is not recommended to calibrate using a calibration gas because we believe the factory calibration is more precise. If a gas calibration is performed, we recommend placing the analyzer back in the Factory Calibration state before placing the analyzer back online. Instructions can be found in the user manual.

If, after properly setting up and running the analyzer, you feel the analyzer should be reading a different value, this may be due to discrepancies between the analyzer's reading and the reading from the cross-check device such as a laboratory analyzer, etc. This is because the Model 205 and the laboratory analyzer are likely using two different principles of operation, two different standards, and two different operators.

Further discrepancy between the model 205 and a lab analyzer may be in the sample handling. The Model 205 is operating in a "closed loop" system. No H<sub>2</sub>S is escaping during the measurement. However, which



a lab analyzer a sample must somehow be collected and transported and finally measured by the lab instrument. This leaves the sample exposed to the environment and therefore could result in the evaporation of H<sub>2</sub>S. H<sub>2</sub>S is a very volatile component that is prone to dissipation if not handled correctly in a closed system.

If the need to calibrate the analyzer still exists, or if the stripping efficiency of the STS is questioned, the analyzer should first be cleaned to insure contamination has not affected the membrane stripping efficiency over an extended period of time. Next a liquid standard can be prepared and used to validate the analyzer reading. If this is not successful a calibration kit can be purchased from Analytical Systems KECO and the analyzer re calibrated. This requires the factory to send a "Calibration Module" that can be uploaded to the analyzer to modify the calibration. To prepare a Calibration Module, the factory must know 1) the present reading of the Model 205, and 2) the "correct" value the Model 205 is believed should be reading. Please send an email to [support@kecosystems.com](mailto:support@kecosystems.com) if this is desired and arrangements can be made to purchase a Calibration Module.

Please contact the factory for any questions: [support@kecosystems.com](mailto:support@kecosystems.com) or 1+ (281) 255-6537.

[www.liquidgasanalyzers.com](http://www.liquidgasanalyzers.com) | [support@kecosystems.com](mailto:support@kecosystems.com) | [sales@kecosystems.com](mailto:sales@kecosystems.com) |

# TYPICAL

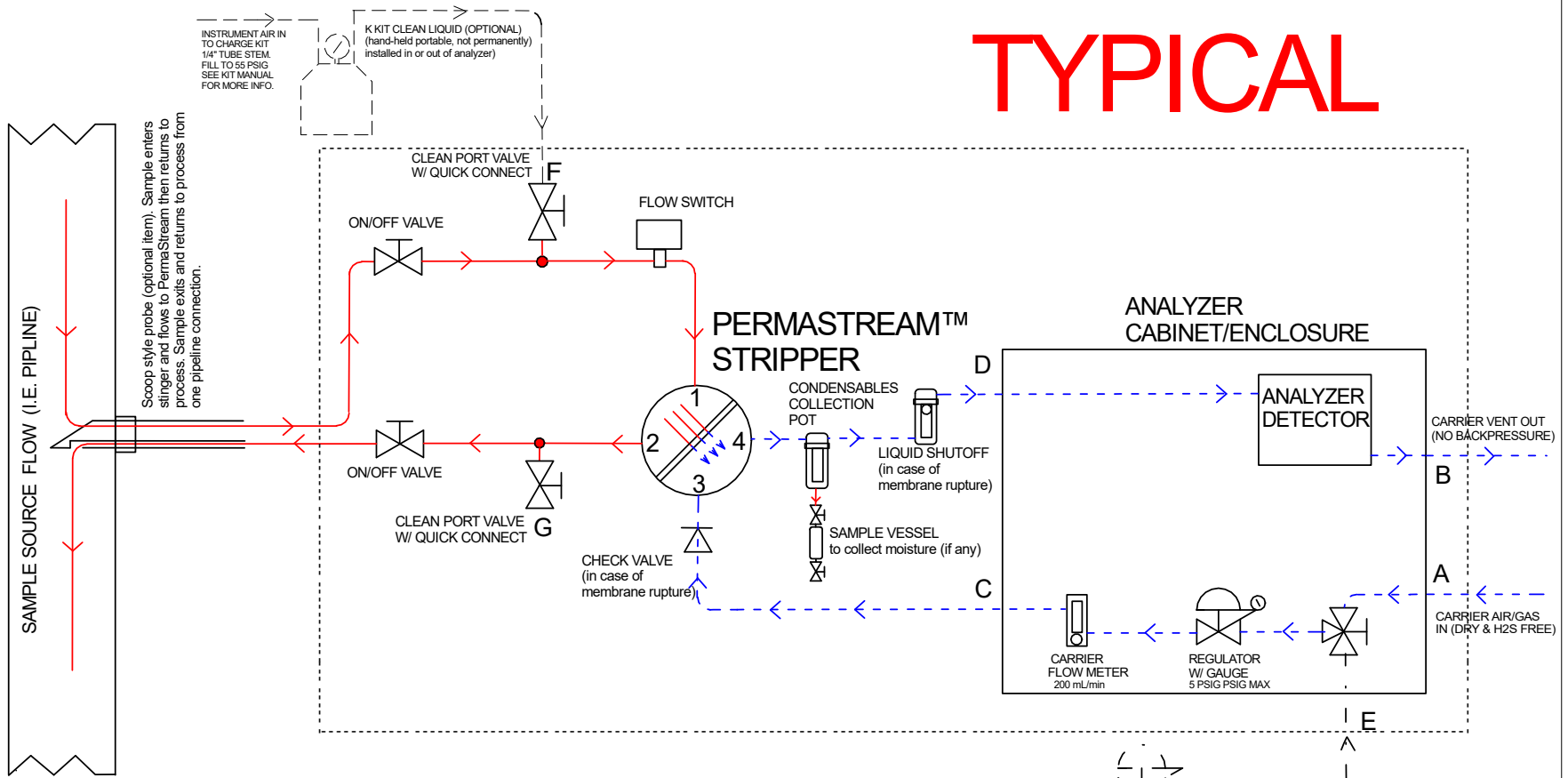

- SAMPLE FLOW
- CARRIER AIR/GAS - 1/8" TUBING.  
HEAT TRACED with variable temp. control  
From 30C to 60C (to be provided by others) Set to 40C
- CAL GAS
- CLEAN KIT

1. Sample Input - 3/4" Tube Fitting (1/2L/min. flow)
2. Sample Output - 3/4" Tube Fitting
3. Carrier Air/Gas Input - 1/8" Tube Fitting
4. Carrier Air/Gas Output - 1/8" Tube Fitting
- A. Carrier Air/Gas Input to Analyzer/Detector - 1/8" Tube Fitting
- B. Carrier Air/Gas Vent from Analyzer/Detector - 1/4" Tube Fitting (NO BACK-PRESSURE)
- C. Carrier Air/Gas Output to PermaStream - 1/8" Tube Fitting
- D. Carrier Air/Gas Input (vapor phase sample) to Analyzer/Detector (stripped sample) - 1/8" Tube Fitting
- E. Cal Gas Input - 1/8" Tube Fitting
- F. Cleaning Fluid Input - 1/4" Quick Connect
- G. Cleaning Fluid Output - 1/4" Quick Connect

ALL FITTINGS ARE SWAGELOK 316SS

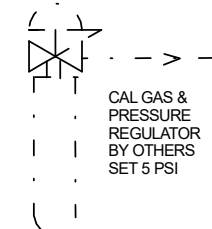

NOTE: If analyzer/detector is being supplied by ASK (optional), consult analyzer drawings and manual for proper installation procedures and specifications.

Phone (281) 516-3950			ANALYTICAL SYSTEMS KECO			FAX: 281-351-8925		
SCALE: NTS		APPROVED BY:			DRAWN BY: DP			
DATE: 02/2020								
SAMPLE/CARRIER FLOW PERMASTREAM								
<b>CONFIDENTIAL</b>								

REVISIONS:



# TYPICAL

## HEATED ENCLOSURE

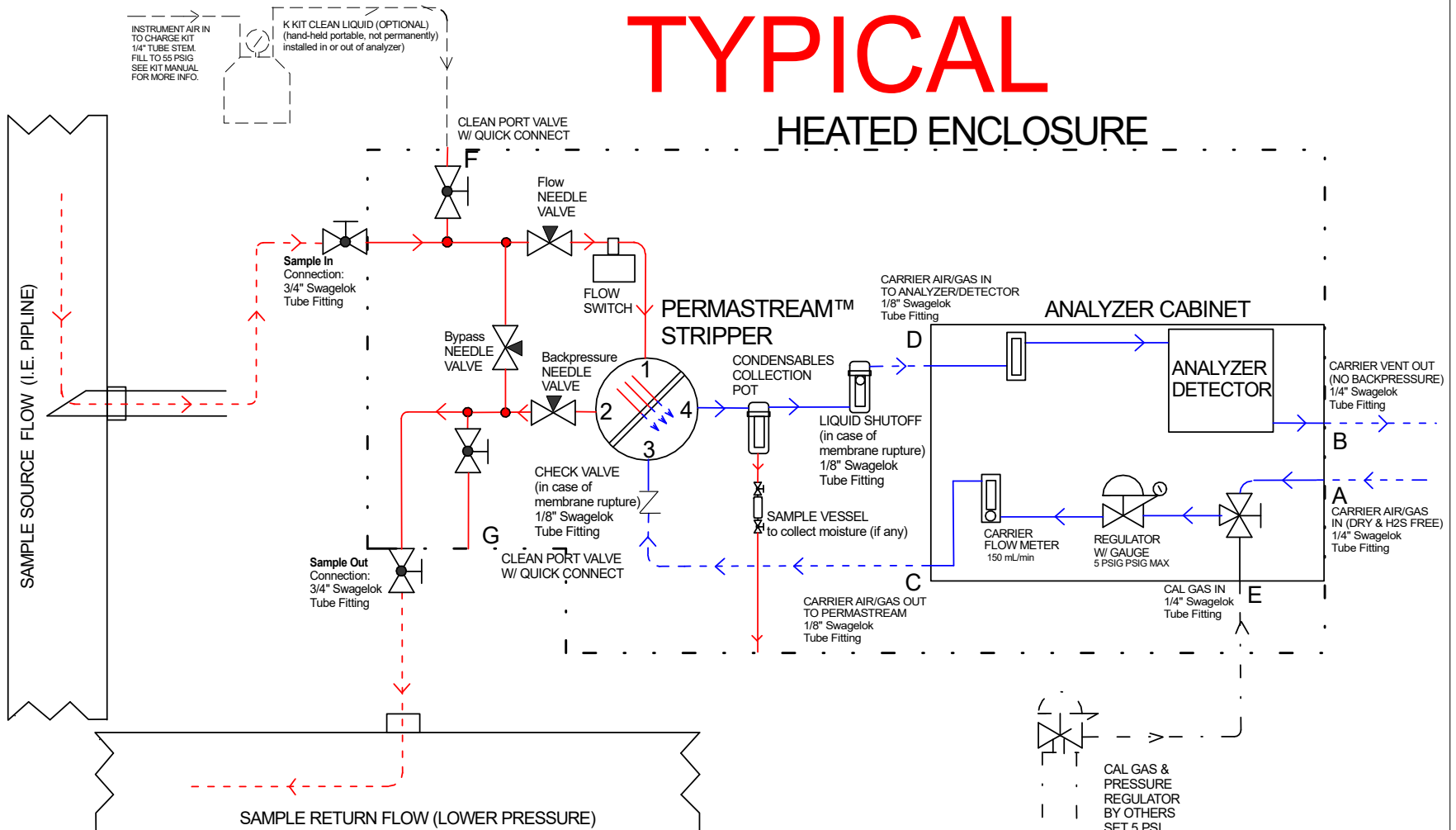

- - - - - SAMPLE 3/4" SS TUBING (PROVIDED BY CUSTOMER) - Heat Traced by customer
- - - - - SAMPLE 3/4" SS TUBING (PROVIDED BY ASKECO) - Heat Traced by customer
- - - - - CARRIER AIR/GAS - 1/8" TUBING. (PROVIDED BY CUSTOMER)  
HEAT TRACED by customer with variable temp. control  
From 30C to 60C (to be provided by others) Set to 40C
- - - - - CARRIER AIR/GAS - 1/4" TUBING (PROVIDED BY ASKECO)  
Heat Traced by customer
- - - - - CAL GAS
- - - - - CLEAN KIT

1. Sample Input - 3/4" Tube Fitting (1/2L/min. flow)
2. Sample Output - 3/4" Tube Fitting
3. Carrier Air/Gas Input - 1/8" Tube Fitting
4. Carrier Air/Gas Output - 1/8" Tube Fitting
- A. Carrier Air/Gas Input to Analyzer Cabinet - 1/4" Tube Fitting
- B. Carrier Air/Gas Vent from Analyzer/Detector - 1/4" Tube Fitting (NO BACK-PRESSURE)
- C. Carrier Air/Gas Output to PermaStream - 1/8" Tube Fitting
- D. Carrier Air/Gas Input (vapor phase sample) to Analyzer/Detector (stripped sample) - 1/8" Tube Fitting
- E. Cal Gas Input - 1/4" Tube Fitting
- F. Cleaning Fluid Input - 1/4" Quick Connect
- G. Cleaning Fluid Output - 1/4" Quick Connect

ALL FITTINGS ARE SWAGELOK 316SS

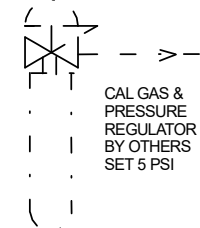

NOTE: If analyzer/detector is being supplied by ASK (optional), consult analyzer drawings and manual for proper installation procedures and specifications.

### REVISIONS:

Phone (281) 516-3950		ANALYTICAL SYSTEMS KECO		FAX: 281-351-8925	
SCALE: NTS	APPROVED BY:	DRAWN BY: DP			
DATE: 02/2020					
PS-H2S-T222PS FLOW DIAGRAM PERMASTREAM - OPEN LOOP					



# Left Side View

# Front View

# Right Side View

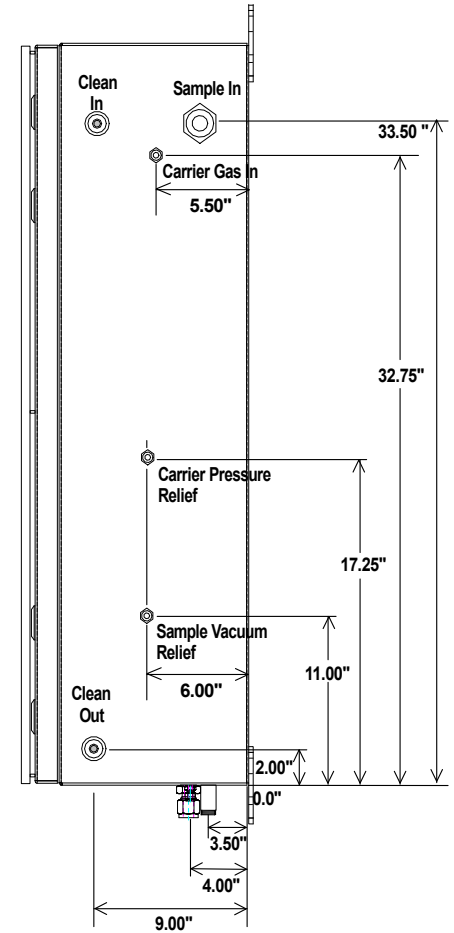
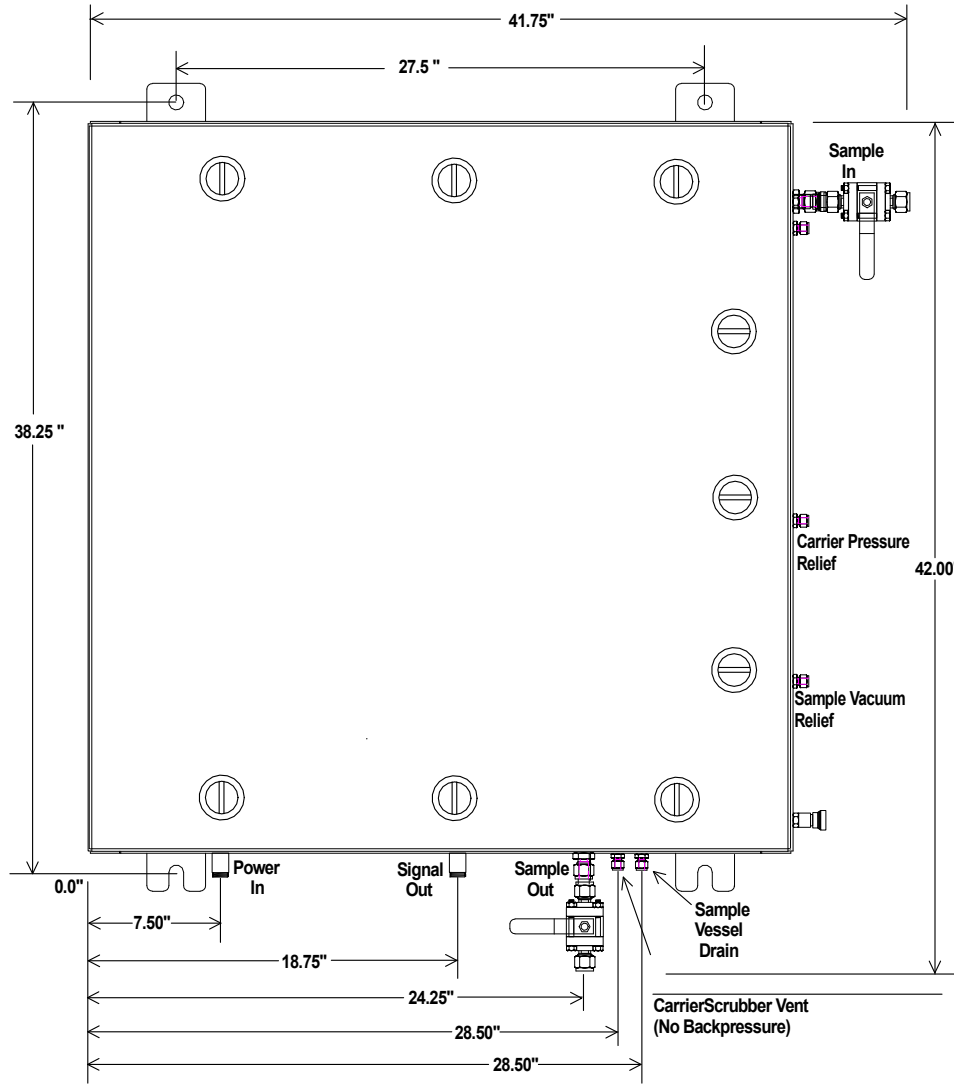
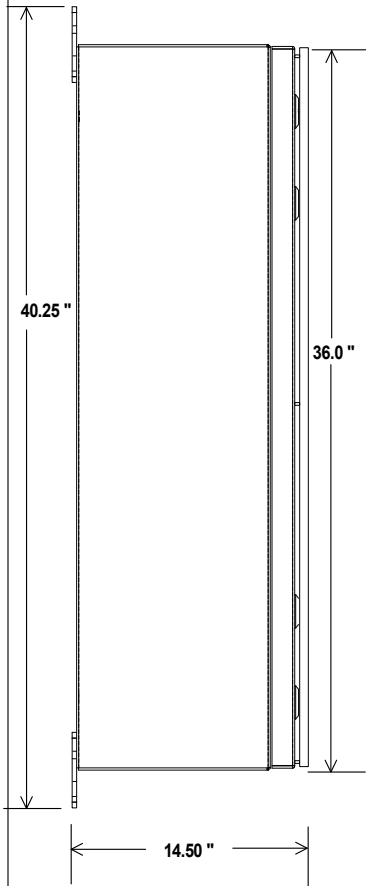

**TYPICAL**

REVISIONS:

Phone: 281-516-3950		<b>KECO</b>		FAX: 281-351-8925
SCALE:	APPROVED BY:	DRAWN BY: DBG		
DATE: 12/2020		WO		
CABINET CONNECTIONS & DIMMENSIONS 205-PermaStream				
File:		PEnclosure Conn Dimms		

120 VAC  
60 Hz

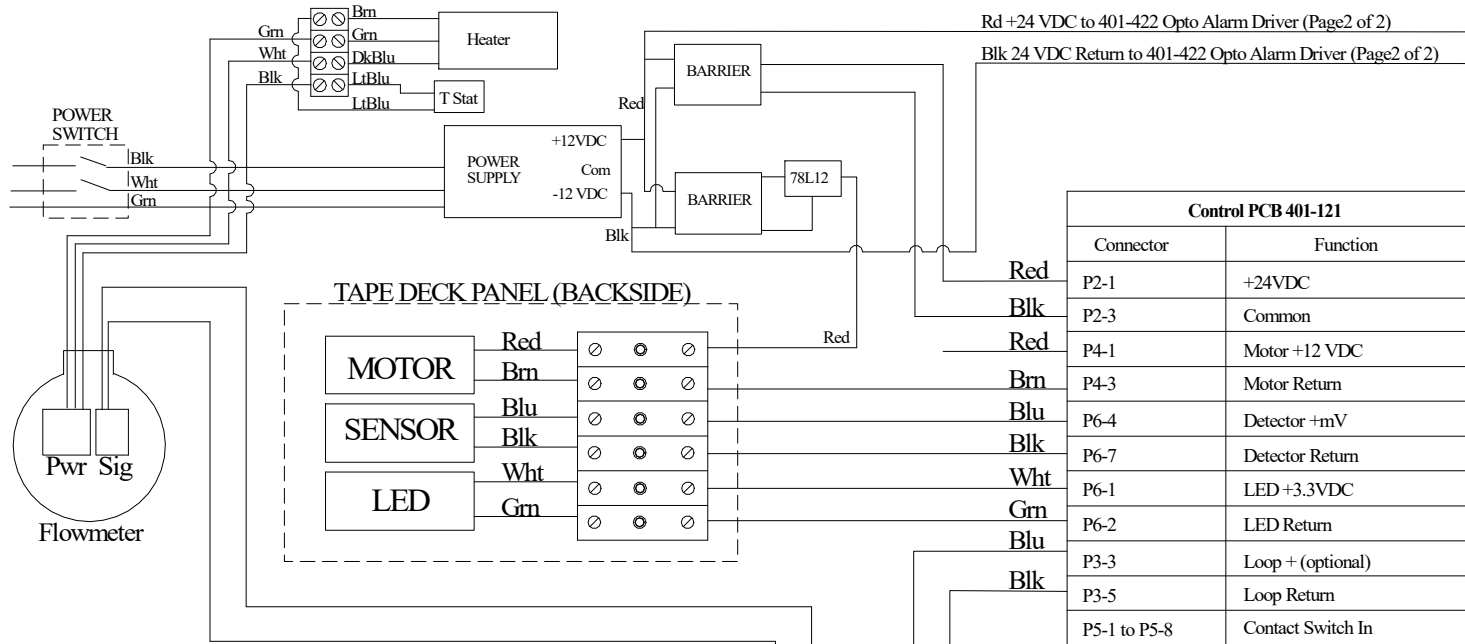

Rd +24 VDC to 401-422 Opto Alarm Driver (Page2 of 2)  
Blk 24 VDC Return to 401-422 Opto Alarm Driver (Page2 of 2)

Control PCB 401-121	
Connector	Function
P2-1	+24VDC
P2-3	Common
P4-1	Motor +12 VDC
P4-3	Motor Return
P6-4	Detector +mV
P6-7	Detector Return
P6-1	LED +3.3VDC
P6-2	LED Return
P3-3	Loop + (optional)
P3-5	Loop Return
P5-1 to P5-8	Contact Switch In
P5-9	Contact Common
P1-1 to P1-8	Loop Expansion (optional)
P7-1	2.5 VDC
P7-2	Flowmeter Signal
P7-3 to P7-4	A/D Aux
P7-5	Flowmeter +5VDC
P7-7	Common
J2-1	Contact Out +3.3VDC
J2-2 to J2-16	Contact Out Drive

Measurement PCB 401-221	
Connector	Function
P7-1	RS-485 A+
P7-2	RS-485 B-
P7-3	RS-485 Ground/Sheild

CUSTOMER CONNECTIONS

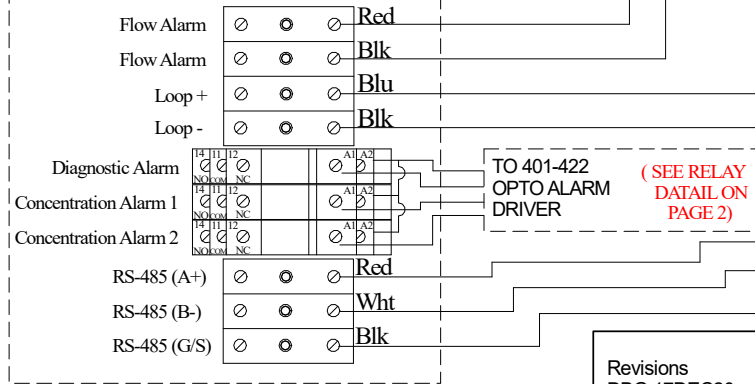

TO 401-422  
OPTO ALARM  
DRIVER (SEE RELAY  
DATAIL ON  
PAGE 2)

# TYPICAL

NOTES  
J2-2 TO J2-16 MAX 5VDC, SINK 0.005 A EACH

Revisions  
DBG 17DEC20

Ph: (281) 516-3950 sales@ASIKECO.COM  
 Fx: (281) 351-8925 WWW.ASIKECO.COM  
 SCALE: NONE DRAWN BY: DLF  
 DATE: 11DEC20  
 Wiring Page 1 of 2 Control PCB 205- PermaStream ANALYZER  
 SHEET 1 of 2 DRAWING NO: Wire P1 212 -



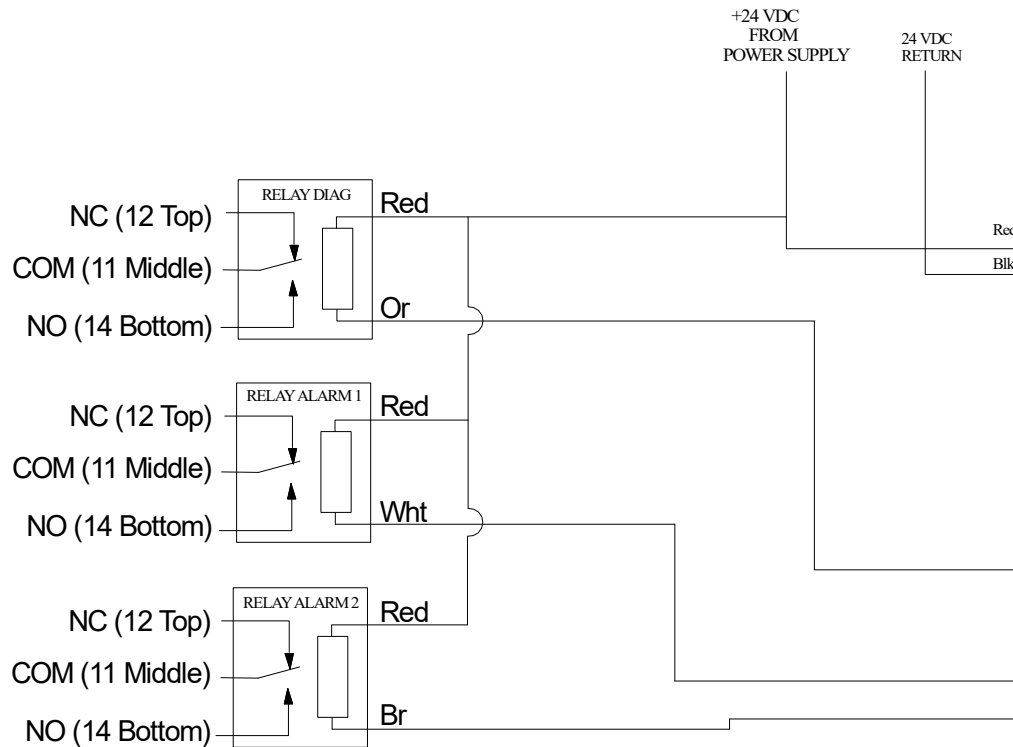

401-422 OPTO IF ALARM DRIVER	
CONNECTOR	FUNCTION
TB1-1	+24VDC
TB1-2	+24VDC Return
TB4-1	+24VDC
TB4-2	24VDC Return
TB2-1	OPTIONAL
TB2-2	OPTIONAL
TB2-3	OPTIONAL
TB2-4	OPTIONAL
TB2-5	OPTIONAL
TB2-6	OPTIONAL
TB2-7	OPTIONAL
TB3-8	DIAGNOSTIC ALARM
TB3-2	OPTIONAL
TB3-3	OPTIONAL
TB3-11	CONCENTRATION ALARM 1
TB3-12	CONCENTRATION ALARM 2
TB3-6	OPTIONAL
TB3-7	OPTIONAL
P1-1	+3.3 VDC FROM 401-121 PCB
P1-2 to P1-16	CONTROL SIGNAL FROM 401-121 PCB

# TYPICAL

NOTES
TB2-1 to TB2-7 MAX 36VDC 0.2A SINK EACH SOURCE 0.0 A
TB3-1 TO TB3-7 MAX 36VDC 0.2A SINK EACH SOURCE 0.0 A
TB4-1 AND TB4-2 ALTERNATE CONNECTORS FOR +12 VDC AND 12 V RETURN (COMMON)
P1-2 TO P1-16 MAX 5VDC, SINK 0.005 A EACH

Revisions DBG 17DEC20
--------------------------

Ph: (281) 516-3950		sales@ASIKECO.COM
Fx: (281) 351-8925		WWW.ASIKECO.COM
SCALE: NONE		DRAWN BY: DLF
DATE: 11DEC20		
Wiring Page 2 of 2 Control PCB 205-PermaStream ANALYZER		
Sheet 2 of 2	DRAWING NO: Wire P2 212	